

METHODS FOR MEASUREMENT OF THERMAL CONDUCTIVITY AND  
SPECIFIC HEAT AT MODERATE, LOW, AND CRYOGENIC  
TEMPERATURES

E. S. Platonov

UDC 681.2:536.083

Physical principles and schematic diagrams of automated devices for measurement of thermophysical properties of materials and components in the temperature range 100-700 K are presented.

Recent decades have been characterized by an increased interest in study of thermophysical properties of materials which must operate over wide temperature ranges. To create highly efficient dynamic methods and equipment for experimental determination of thermal conductivity and specific heat of industrial materials used in refrigeration and cryogenic technology, in 1977 at the Leningrad Refrigeration Industry Technological Institute a separate scientific-research laboratory operating in close contact with the State Thermophysical Instrument Engineering Committee was organized. In the following 10 years this laboratory has performed a series of interesting studies, many of which resulted in creation of a new generation of domestic thermophysical equipment provided with direct readout units or systems for automated control of experiments and computer processing of measurement results. Their operating specifications are not exceeded by the best available foreign products, and some are beginning to enter regular industrial production.

Devices intended for measurements under normal climatic conditions form an independent group of developments. Despite the wide range of thermophysical measurement methods available under normal climatic conditions, there is still a necessity for developing new devices which consider more fully structural specifics and use conditions of modern technical materials. Thus the laboratory developed a group of direct readout instruments for use with specimens of the most universal form - disks 15-40 mm in diameter with thicknesses of 0.5-20 mm [1].

A generalized schematic diagram of the thermal cell used in these devices is shown in Fig. 1. Measurements are made with this device using the principle of heating of a disk with uniform initial temperature field with boundary conditions of the first sort. The thermal cell is based on two massive metallic blocks 1, 3, one of which is at room temperature (temperature of the medium), while the second is heated by heater 4 to a temperature 5-15 K above that of the medium. During experiment the blocks are located in contact with the planar faces of the specimen 2, and the thermal fluxes passing through them into the specimen  $q_u(\tau)$  and  $q_l(\tau)$  (see Fig. 2) are recorded by two gradient thermometers 5 and 6, installed in the working area of the blocks.

This experimental regime is convenient for a number of reasons. In particular, it makes it unnecessary to record the nonsteady state temperature field of the specimen or maintain constant temperature levels on its plane faces. To determine thermal conductivity it is only necessary to know the temperature head between the blocks (within the specimen) and the steady state thermal flux passing through the specimen  $q_c = q(\tau_c)$ . In turn, to determine specific heat of the specimen it is sufficient to establish the quantity of heat accumulated within the specimen over the time of the experiment, by integrating over time the difference in the

indications of the thermometers  $Q = \int_0^{\tau_c} (q_u - q_l) d\tau$ , i.e., to calculate the shaded area in Fig.

---

Refrigeration Industry Technological Institute, Leningrad. Translated from *Inzhenerno-Fizicheskii Zhurnal*, Vol. 53, No. 6, pp. 987-994, December, 1987. Original article submitted April 21, 1987.

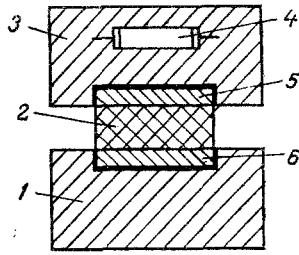

Fig. 1

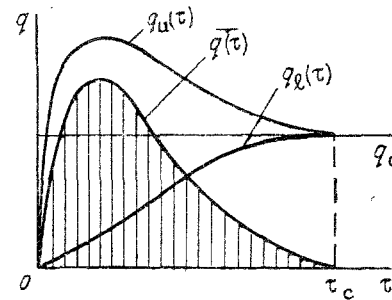

Fig. 2

Fig. 1. Diagram of thermal cell for normal climatic conditions.

Fig. 2. Thermal fluxes  $q_u(\tau)$  and  $q_l(\tau)$  at specimen boundaries in normal climatic condition devices.

2. If the device is intended for measurement of thermal conductivity only, only one thermometer need be used. This significantly simplifies alignment and use of the devices as well as the circuitry used for direct readout.

The chosen regime provides a successful combination of operating parameters. Thus, for bulk measurements the duration of a single experiment is determined only by the internal thermal inertia of the specimen and comprises  $\tau \sim (h^2/4a)$ . The initial unproductive stage of exit of the upper block to the specified temperature level usually requires no more than 10 min, while the thermal state of the blocks has practically no effect on subsequent measurement length. It is also significant that the gradient thermometers built into the device permit calibration with samples having well known thermal properties (reference specimens) and adjustment of sensitivity by external electrical circuits, which greatly simplifies alignment and testing of the devices.

If specimens having a specific thermal resistance  $h/\lambda = (2-10) \cdot 10^{-3} \text{ m}^2 \cdot \text{K/W}$  are used, the uncertainty in  $\lambda$  and  $c$  determination is usually no greater than 3-5%.

Another large group of devices is instruments which permit measurement of thermal properties of construction elements without taking samples or preparation of special specimens, in other words, devices for nondestructive thermal testing [2-4]. Development of effective methods for nondestructive testing, including thermal testing, has been given great attention in recent years. It is known that many materials, especially thermal insulation materials, have thermal properties which degrade with time. Under use conditions such changes are unpredictable, so that for quantitative estimates it is necessary to perform periodic nondestructive thermal testing of elements of the finished equipment.

In developing methods for nondestructive thermal testing certain difficulties have appeared, the main ones involving the significant inertia of thermal processes and the absence of methods for directed local nondestructive thermal probing in the inner layers of parts. This significantly limits the capabilities of such methods. However, there remain many technological processes and industrial objects which require methods of direct nondestructive thermal testing and do not allow use of possible correlations between thermal and other physical properties of the materials.

Constant power surface thermal sources (planar, linear, or point) are usually used for thermal probing in such devices. Occasionally impulsive thermal sources are used. Studies performed in the laboratory indicated the promise of other thermal techniques, in particular, isothermal ones [2]. Such a technique is useful when the portion of the part to be tested can be treated as a homogeneous semispace  $l$  (Fig. 3). The parameter recorded experimentally can then be either the thermal flux  $q(\tau)$  flowing into the part through the surface, or the

quantity of heat accumulated by the bar  $Q = \int_0^{\tau_c} q d\tau$  (Fig. 4). For recording the thermal flux

$q(\tau)$  gradient thermometers 2 can be used (Fig. 3). In the second variant it is convenient to use enthalpic metallic thermometers, since they can serve directly as isothermal probes 3, these being massive metallic cores protected by an adiabatic shell 4 from the surrounding medium. Isothermal probes provided with a gradient thermometer are more convenient for testing of thermal insulation coatings. On the other hand, the enthalpy method is preferable for testing construction elements with a significant thermal conductivity.

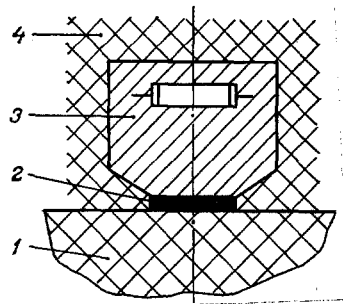

Fig. 3

Fig. 3. Thermal cell for nondestructive testing with isothermal interaction.

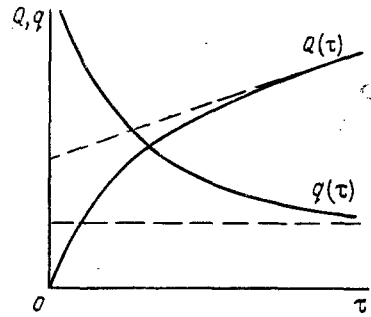

Fig. 4

Fig. 4. Change in  $Q(\tau)$  and  $q(\tau)$  on working surface of part for isothermal interaction.

Isothermal thermal techniques permit simultaneous determination of the local thermal conductivity and thermal activity  $\epsilon_a = \sqrt{\lambda c \rho}$  of a part. The duration of the measurement depends primarily on the size of the probe contact area and the thermal activity of the material. The active stage of the experiment is that with  $Fo = a\tau/r_0^2 \leq 1$ .

Thermal insulation coatings (Fig. 5) are usually constructed as relatively thin layers 2, deposited on a metallic base 1 and protected on the outer surface by a thin layer of construction material 3 (metallic or polymer). Nondestructive testing of such details is an independent problem. For example, to measure their thermal resistance, the method of free cooling of a metallic thermoprobe-disk introduced into thermal contact with the coating surface is quite convenient [3, 4].

A thermal model of measurements made by this method is shown in Fig. 5. The thermoprobe consists of a metal disc 4, its outer surface shielded from the surrounding medium by an adiabatic shell 4, composed of a metallic cup 5, heater 6, and thermal insulation 7. A control system (not shown in the figure) insures equality of cup and disc temperatures. Like the disc, the annular surface of the cup contacts the thermal coating, eliminating heat loss along the coating and insuring a uniform planar temperature perturbation in the disc-coating-thermal insulation layer system.

The essential stage of operation in such normal condition thermal probes is the regular stage of the experiment. But in contrast to widely known regular regime methods (for example, bicalorimeters) here we must consider the initial thermal state of the system and features of the transient stage of the experiment in order to evaluate the effective specific heat of the studied coating and consider the effect of the latter on the thermal resistance.

Uncertainty in determining specific thermal resistance of insulation coatings using these normal climatic condition devices usually comprises 5-10%.

The laboratory performed studies on improvement of previously developed and industrially produced thermophysical devices of the LT-400 type, designed for simultaneous determination of thermal conductivity and specific heat in the traditional 150-700 K temperature range. These studies were performed to create a second generation of industrially produced devices, so the established specimen sizes (discs 15 mm in diameter, 1-20 mm thick) and monotonic heating regime were retained.

A diagram of the thermal cell of one of these new IT-400 type devices is shown in Fig. 6. The specimen 2 and two metal (copper) plates 1, 3 containing electrical heaters form a system separated from the medium by several adiabatic shells. After preliminary cooling to the specified lower temperature level the specimen-plate system is monotonically heated by the two heaters with different thermal fluxes  $q_l(\tau)$  and  $q_u(\tau)$ . The values of these fluxes are chosen so that the cell heats at an approximate rate of  $b \sim 0.1$  K/sec at a temperature head of  $\theta_{lu}(\tau) = t_l(\tau) - t_u(\tau)$ , not exceeding the range 5-30 K. Use of two independent heaters markedly improves the technical capabilities of the device. Thus it is possible to perform combined determinations of  $\lambda(t)$  and  $c(t)$  of materials over an expanded parameter range: for  $\lambda$  from 0.1 to 100 W/(m·K) and  $c_p$  from 50 J/(m<sup>3</sup>·K) and above. Uncertainty in  $\lambda$  and  $c$  measurement does not exceed 3-5%.

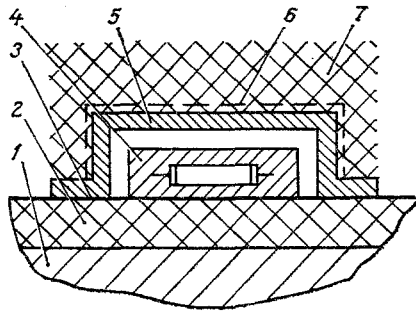

Fig. 5

Fig. 5. Diagram of thermal cell for nondestructive testing of thermal insulation coatings.

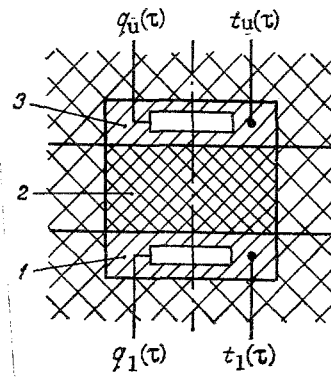

Fig. 6

Fig. 6. Thermal cell of IT-400 type device for simultaneous  $\lambda(t)$  and  $c(t)$  measurements.

However it should be noted that realization of these improved specifications is made possible not only by the thermal cell configuration chosen (which is quite traditional) but by the multifunction adiabatization system developed for the cell, consisting of three coarse and two fine automatic regulation systems. This system permits elimination of gradient thermometers, which usually introduce significant uncertainty because of instability in their characteristics and in addition require periodic individual calibration.

In this model of the device a simplified system for cooling the cell to liquid nitrogen temperature has proved itself. The cell and adiabatic shells readied for experiment are lowered on a rod into a special vessel containing liquid nitrogen, cooled therein until all the nitrogen boils away, and then monotonically heated by the heaters to a specified upper temperature level while remaining in the vessel, the walls of which then serve as thermal insulation. This cooling system has proven quite reliable and economical with regard to nitrogen expenditure, and facilitates preparation of the cell for experiment.

Here we should call attention to yet another important feature of this device: the measurements performed with it are absolute in nature, and cell calibration with reference specimens is not required. The latter are useful only for periodic testing of device function during use. Because of the difficulties of providing users with reference specimens this tendency has become characteristic of industrial thermophysical instrumentation, although it undoubtedly leads to complication of device thermal cells, especially their adiabatization systems and specification of boundary conditions.

To study thermal conductivity of electrically conductive materials (metals, etc.) steady state electrical methods for axial heating of bars are used most often. However they cannot be considered successful with regard to convenience, their major shortcomings being low output and difficulties in preparing for measurements. In connection with this the laboratory studied possible paths of refining electrical methods, suitable for determination of metal thermal conductivities over a wide temperature range, from 120 to 1000 K. Several variants of nonsteady state heating (cooling) of bars subjected to combined thermal actions were considered.

The essence of the variants developed can be reduced to the constant section, is attached at its ends to the face portions of a two-piece metal shell 2, such that its central portion is separated from the shell walls by a cylindrical air (or vacuum) cavity. In the general case the cavity may contain a thin-wall metal tube 3 with independent electrical heater, performing the function of an adiabatic shell. With the aid of a heating (cooling) system the shell and specimen are caused to change temperature at a slowly changing rate. The specimen is additionally heated by an electrical current (internal Joulean source). The regulation system provides a temperature field within the cell which is symmetric relative to the central cross section of the specimen:  $t_\ell(\tau) \approx t_{-\ell}(\tau)$ . The combined nonsteady state thermal action permits experimental determination of thermal conductivity, heat capacity, and electrical conductivity of the specimen as functions of temperature. Variants of this cell with different rules for action of the external heat source have been studied and justified [6, 7]. Uncertainties in determining all three characteristics of the metal correspond to the contemporary level of practical requirements.

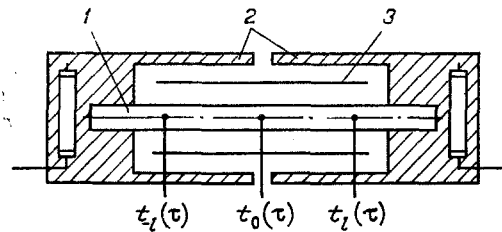

Fig. 7. Diagram of thermal cell for metals.

As has already been noted, in recent years an increased interest has developed in studies of thermophysical properties of materials in the hydrogen and helium temperature range. There are special difficulties involved in designing experimental equipment for this temperature range. The most significant of these are the complexity of temperature stabilization, recording of precise local temperatures, consideration of the intense nonlinearity in thermal conductivity processes characteristic of cryogenic temperatures, and finally, insurance of reliable thermal contact. For this reason the methods most widely used so far are steady-state methods for determination of thermal conductivity and impulsive steady state for specific heat. Our laboratory has carried out studies on nonsteady-state methods of monotonic heating (cooling), obtaining encouraging results for the first time. Achievements have been made in shortening the duration and complexities of experiment, together with simplifications of thermal cell construction. One feature of the experimental devices developed is that they require no special cryostat, the thermal cell being lowered directly through the neck of a transport Dewar flask containing liquid helium.

To measure the effective thermal resistance and heat accumulation capability of structural and thermal insulation slabs, a special device was created, designed for standard specimens  $250 \times 250 \times 50$  mm [8]. The measurement method is based on the principles of transition of the studied plate from the original steady state with a uniform temperature field (room temperature) to a final steady state with asymptotic boundary conditions of the first sort. During the experiment we record thermal fluxes penetrating both boundaries of the plate, for which, for example, one can use gradient thermometers, constructed with double-sided foil. The basic scheme of the thermal cell coincides with that shown in Fig. 1, differing only in that the upper and lower blocks are provided with heater and cooler units, and for preliminary stage of the experiment specified temperature levels are generated. The working temperature range of the apparatus comprises 100-400 K, with measurement uncertainty of  $\sim 3-5\%$ .

Amongst the studies performed at the laboratory, a special place is occupied by those related to determination of thermophysical characteristics based on numerical solution of converse thermal conductivity problems. Studies of this nature are well known and appear promising in cases where within the experiment it is difficult to separate a stage with structurally simple analytic expressions for the temperature field within the specimen, in particular for determination of thermophysical characteristics as functions of temperature in coarsely dispersed thermal insulation materials. Of special interest here are measurement methods in which the experimental data is collected only from outer faces of the specimen, i.e., methods which do not require introduction of thermocouples or thermometers into internal layers. The laboratory developed a method for calculating  $\lambda(t)$  and  $c(t)$  of slabs from experimental data on nonsteady-state temperatures and thermal fluxes on their plane faces [9]. If processes within the studied slab are not complicated by phase transitions, the uncertainties in  $\lambda(t)$  and  $c(t)$  calculations fully satisfy modern technical requirements, usually comprising 5-7%.

As has already been noted all the thermophysical devices and equipment developed in the laboratory are provided with individual computers (microprocessor direct readout circuits) or operate with an Elektronika DZ-28 microcomputer as a controller. Interface circuitry contains special dc amplifiers with  $\mu\text{V}$  sensitivity thresholds.

More detailed information on construction features and mathematical operating principles of the device developed at the laboratory in collaboration with the State Thermophysical Instrument Engineering Committee can be found in [1-9], and partially, in the monograph [10]. The review [11] will give some concept of the overall state of thermophysical instrumentation in the Soviet Union and abroad.

## NOTATION

$\tau$ , time;  $t$ , temperature;  $\theta$ , temperature difference;  $b$ , heating rate;  $q$ , thermal flux;  $Q$ , heat absorbed;  $\lambda$ , thermal conductivity;  $a$ , thermal diffusivity;  $c$ , specific heat;  $\rho$ , density;  $\varepsilon_a$ , thermal activity;  $h$ , specimen thickness;  $r_0$ , contact spot radius.

## LITERATURE CITED

1. V. V. Kurepin, V. M. Kozin, and Yu. V. Levochkin, *Promyshl. Teplotekh.*, 4, No. 3, 91-97 (1982).
2. E. A. Belov, V. V. Kurepin, and N. V. Nimenskii, *Inzh.-Fiz. Zh.*, 39, No.3, 463-466 (1985).
3. E. A. Belov, G. Ya. Sokolov, and E. S. Platonov, *Promyshl. Teplotekh.*, 8, No. 4, 56-60 (1986).
4. E. A. Belov and G. Ya. Sokolov, *Zavod. Lab.*, 52, No. 2, 55-56 (1986).
5. V. M. Kozin, G. Ya. Sokolov, and E. S. Platonov, *Izv. Vyssh. Uchebn. Zaved., Priborostr.*, 29, No. 3, 90-96 (1986).
6. S. E. Buravoi, E. S. Platonov, and V. A. Samoletov, *Promyshl. Teplotekh.*, 5, No. 5, 102-105 (1983).
7. V. A. Samoletov, *Izv. Vyssh. Uchebn. Zaved., Priborostr.*, 28, No. 9, 79-82 (1985).
8. "Device for measurement of thermal conductivity and specific heat of materials," Inventor's Certificate No. 1198421: MK14 G 01 N 25/18.
9. N. V. Nimenskii and E. S. Platonov, *Izv. Vyssh. Uchebn. Zaved., Priborostr.*, 27, No. 2, 89-93 (1984).
10. E. S. Platonov, S. E. Buravoi, V. V. Kurepin, and G. S. Petrov, in: *Thermophysical Measurements and Devices* [in Russian], E. S. Platonov (ed.), Leningrad (1986).
11. S. E. Buravoi, V. V. Kurepin, and E. S. Platonov, *Inzh.-Fiz. Zh.*, 30, No. 4, 741-757 (1976).

## CERTAIN PROBLEMS OF FLUID FILTRATION IN ELASTIC CRACKED-POROUS RESEVOIRS

V. S. Nustrov

UDC 532.546

This article examines a procedure for realizing an integral method for filtration processes in an elastically compressible cracked-porous bed.

1. Filtration in a cracked-porous medium (a medium with two systems of channels differing significantly in permeability) is usually modeled on the basis of the representation of two interpenetrating continua which exchange mass. The model in [1] is widely used in filtration theory and practice. The results of the experiments conducted in [2] show, however, that permeability is more heavily dependent on the stress state of the system and fluid pressure in the cracks than is indicated in the representations in [1]. A more complete accounting of the effect of the stress state of the medium on filtration was made in [3]. Here, for the model in [3], we examine certain problems dealing with nonsteady filtration of a fluid toward a well.

2. The below equations [3] describe filtration in the elastic material of an isotropic structure in a state of cubic compression with the stress  $\sigma$  (as well as in the case of two-dimensional filtration in a material in which all cracks are oriented in the plane of motion)

$$a \frac{\partial \psi_1}{\partial t} = \frac{1}{4} \nabla^2 (\psi_1 + 1)^4 + \psi_2 - \psi_1, \quad \varepsilon \frac{\partial \psi_2}{\partial t} = \varepsilon \nabla^2 \psi_2 - \psi_2 + \psi_1, \quad (1)$$